

SCHOTTKY DIODES KDN-10060.

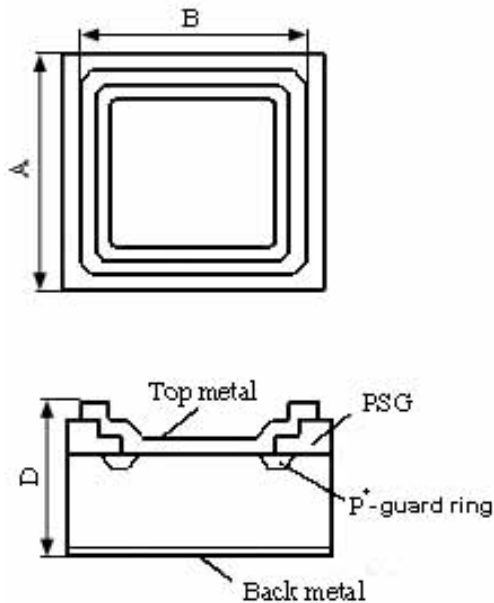

Rev.1. Feb. 2010

 VSP-MIKRON		10A/60V. Die Size-90mil.		
Electrical Characteristics	Symbol	Unit	Spec. limit	Die Sort
Breakdown Voltage @ $I_R=10mA$	V_{BR}	V	60	65
Average Rectified Forward Current	$I_{F(AV)}$	A	10,0	-
DC Forward Voltage @ 25°C, $I_F=10,0A$	V_F	V	0,67	0,65
Maximum Reverse Current @ 25°C, $V_R=65V$ 25°C, $V_R=60V$ 125°C, $V_R=60V$	I_R	mA	- 0,200 110,0	0,200 0,150 100,0
Peak Forward Surge Current 8,3ms single half sine-wave superimposed on rated load (JEDEC METHOD)	I_{FSM}	A	150	-
Peak Repetitive Reverse Surge Current @ 2,0µs, f=1kHz., $T_J<150°C$.	I_{RRM}	A	3,5	
Electrostatic Discharge Voltage. JEDEC Method. ESD HBM. Contact.	ESD	kV	±8 (contact)	
Voltage Rate of Change	dV/dt	V/µS	10.000	
Operating Junction Temperature	T_J	°C	150	



DIM	ITEM	µm
A_x A_y	Wafer Form Die Size	2280 2280
B_x B_y	Top Metal Size	2140 2140
D	Thickness	350max.
Scribe line Width		80

Top metal: a) **Al** – for Wire Bonding;
b) **Al-Ni-Ag** – for Soldering.
Backside metal: **Ti-Ni-Ag**.