

SCHOTTKY DIODES KDN-20020.
PRELIMINARY

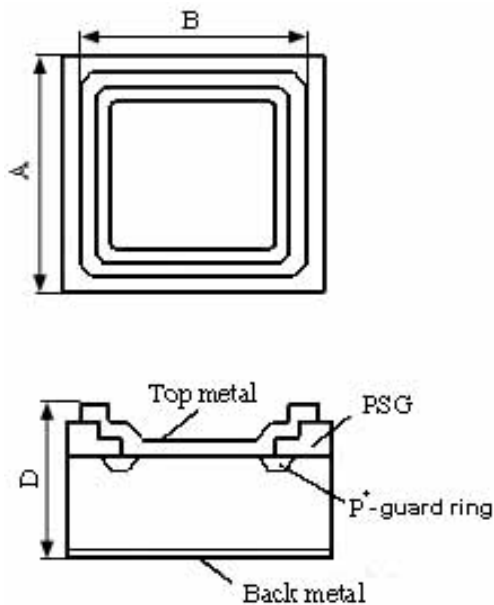

Rev.1. Feb. 2010

 VSP-MIKRON	20A/20V. Die Size-106*138mil.			
Electrical Characteristics	Symbol	Unit	Spec. limit	Die Sort
Breakdown Voltage @ $I_R=10mA$	V_{BR}	V	20	25
Average Rectified Forward Current	$I_{F(AV)}$	A	20,0	-
DC Forward Voltage @ 25°C, $I_F=20,0A$	V_F	V	0,50	0,48
Maximum Reverse Current @ 25°C, $V_R=25V$ 25°C, $V_R=20V$ 125°C, $V_R=20V$	I_R	mA	- 0,450 320,0	0,450 0,400 300,0
Peak Forward Surge Current 8,3ms single half sine-wave superimposed on rated load (JEDEC METHOD)	I_{FSM}	A	250	-
Peak Repetitive Reverse Surge Current @2,0µs, f=1kHz., $T_J<150^\circ C$.	I_{RRM}	A	4,5	
Electrostatic Discharge Voltage. JEDEC Method. ESD HBM. Contact.	ESD	kV	±8 (contact)	
Voltage Rate of Change	dV/dt	V/µS	10.000	
Operating Junction Temperature	T_J	°C	150	



DIM	ITEM	µm
A_x A_y	Wafer Form Die Size	2700 3500
B_x B_y	Top Metal Size	2560 3360
D	Thickness	350max.
Scribe line Width		80

Top metal: a) **Al** – for Wire Bonding;
b) **Al-Ni-Ag**; - for Soldering.
Backside metal: **Ti-Ni-Ag**.