

SCHOTTKY DIODES KDN-40040.
PRELIMINARY

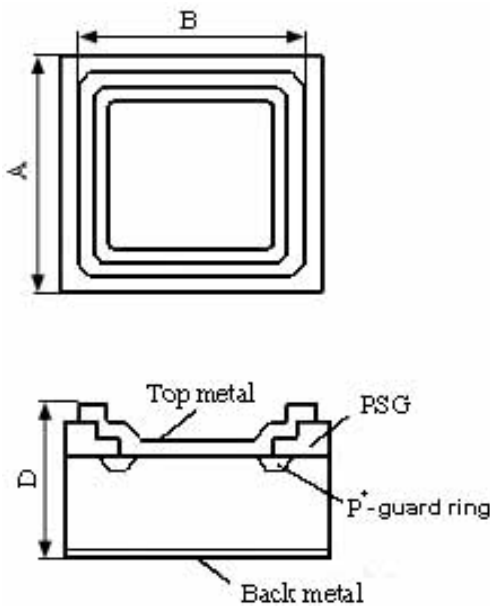

Rev.1. Feb. 2010

	40A/40V. Die Size-150mil.			
Electrical Characteristics	Symbol	Unit	Spec. limit	Die Sort
Breakdown Voltage @ $I_R=10mA$	V_{BR}	V	40	45
Average Rectified Forward Current	$I_{F(AV)}$	A	40,0	-
DC Forward Voltage @ 25°C, $I_F=40,0A$ @ 25°C, $I_F=20,0A$	V_F	V	0,55 0,48	0,53 0,46
Maximum Reverse Current @ 25°C, $V_R=45V$ 25°C, $V_R=40V$ 125°C, $V_R=40V$	I_R	mA	- 0,50 300	0,60 0,40 250
Peak Forward Surge Current 8,3ms single half sine-wave superimposed on rated load (JEDEC METHOD)	I_{FSM}	A	400	-
Peak Repetitive Reverse Surge Current @2,0µs, f=1kHz., $T_J<150°C.$	I_{RRM}	A	5,0	
Electrostatic Discharge Voltage. JEDEC Method. ESD HBM. Contact.	ESD	kV	±8 (contact)	
Voltage Rate of Change	dV/dt	V/µS	10.000	
Operating Junction Temperature	T_J	°C	150	



DIM	ITEM	µm
A_x A_y	Wafer Form Die Size	3810
		3810
B_x B_y	Top Metal Size	3670
		3670
D	Thickness	350max.
Scribe line Width		80

Top metal: a) **Al** – for Wire Bonding;
b) **Al-Ni-Ag** – for Soldering.
Backside metal: **Ti-Ni-Ag**